

XLERATOR Series/Twin Intake Fan

MODEL#: XT1200

FEATURES:

- * Dual intake fan which can be ceiling or wall mount
- * Designed for long duct runs.
- * 120V/60Hz
- * Designed to exhaust two separate rooms with only one exhaust outlet.



MORE FEATURES:

- * Superior Air Performance
- * Typically used in multi-level high static pressure applications
- * Easy access for service and cleaning through hinged motor platform
- * Standard Rubber grommets (noise isolators on mounting brackets)
- * Control systems sold separately (amp sensor and pressure switch)

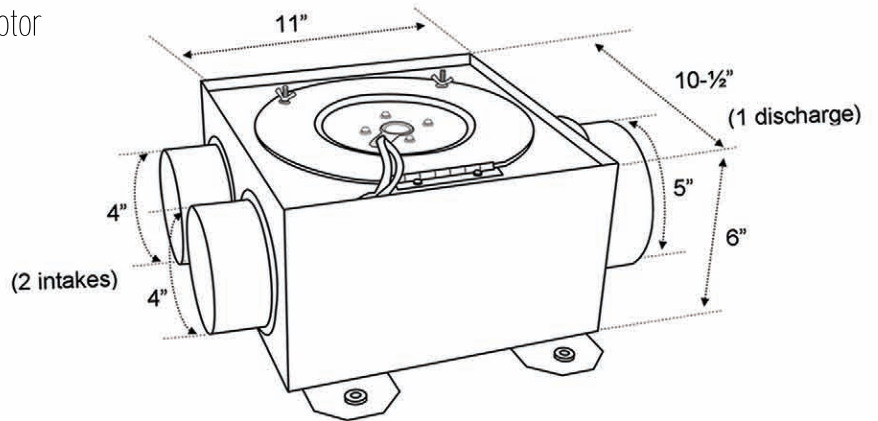

AIR PERFORMANCE (CFM)

Model	Static pressure (inches of wg)													
	0	0.1"	0.2"	0.25	0.3"	0.4"	0.5"	0.6"	0.7"	0.8"	0.9"	1.0"	1.5"	2.0"
XT1200	230	225	215	210	207	197	190	183	175	168	160	150	110	88

Model	RPM (nominal)	Current (amp)	Power (watt)	Electrical rating	Housing (AxBxC)	Intake (D)	Discharge (E)
XT1200	2600	0.9	115	120V/60Hz	10-1/2" x 11" x 6"	2 x 4"	5"

MODEL	QUANTITY	COMMENTS	PROJECT
			Location:
			Architect:
			Engineer:
			Contractor:
			Submitted by:



LEXTON FANS, INC.

5681 SOUTH DOWNEY ROAD
VERNON, CA 90058 USA

Phone: 323-284-2188

Toll Free Fax: 1-866-281-8605

www.lextonfans.com

Certifications:



XLERATOR Series/Twin Intake Fan
 MODEL#: XT1200



AREA FOR A FAN CURVE:

Static Pressure (inches of w.g.):

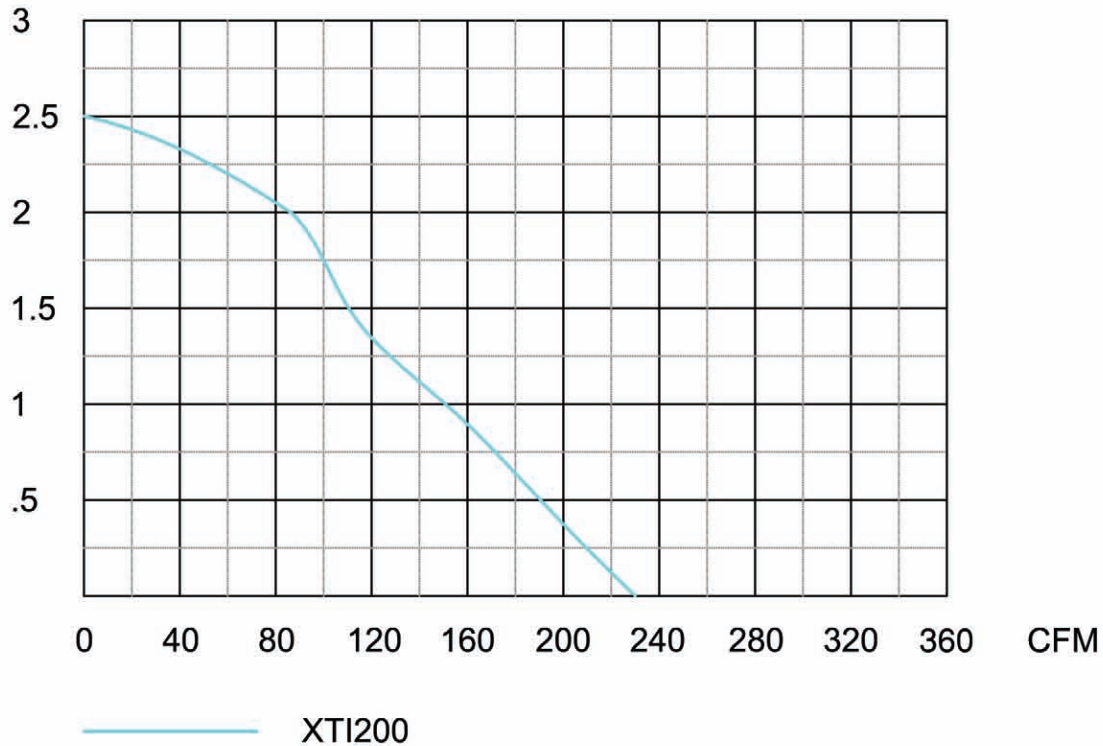

LEXTON FANS, INC.
 5681 SOUTH DOWNEY ROAD
 VERNON, CA 90058 USA
 Phone: 323-284-2188
 Toll Free Fax: 1-866-281-8605

www.lextonfans.com

Certifications:

