



SPECIFICATIONS

VIP Series Ventilation Fan

MODEL#: VIP70, VIP90 & VIP110

DESCRIPTION - Ventilating fan shall be a quiet ceiling mount type rated for continuous run. Fan shall be tested as per AMCA or the Home Ventilating Institute (HVI) standards. Evaluated by ETL and conform to UL safety standards.

MOTOR/BLOWER

- * Four-pole totally enclosed condenser motor rated for continuous run.
- * Power Rating shall be 120/60Hz.
- * Fan shall be ETL listed for tub/shower enclosure when used with a GFCI branch circuit wiring.
- * Motor equipped with thermal cutoff fuse.

FAN HOUSING

- * Galvanized steel housing
- * Detachable 4" diameter duct adapter.
- * Built in backdraft damper.
- * Mounts directly to joist using brackets.
- * Housing Dimensions: 9-1/4" x 9-1/4" x 5-7/8"

GRILLE

- * Attractive design using white ABS material.
- * Attaches directly to housing with torsion springs.
- * Grille Dimensions: 12-1/2" x 12-1/2"

TYPICAL SPECIFICATIONS - Ventilating fan shall be of the ceiling mount with no less than air performance and sound rating as per the following chart tested as per either AMCA or the Home Ventilating Institute (HVI) standards at 0.1" static pressure in inches water gauge. The motor shall be totally enclosed, four pole type engineered to run continuously. Power rating shall be 120V/60Hz. Duct diameter shall be no less than 4". Fan shall be for tub/shower enclosure when used with GFCI branch circuit wiring.

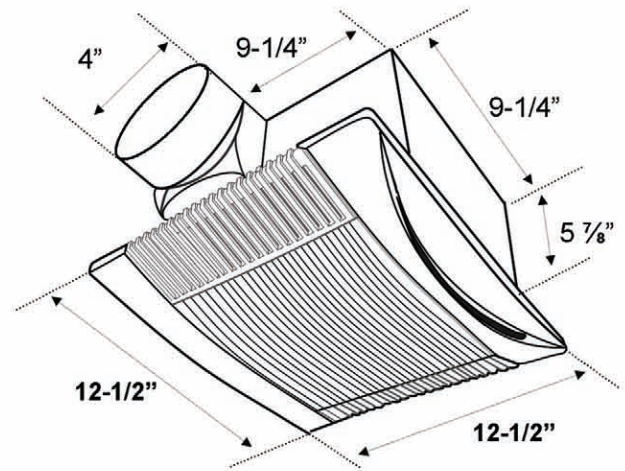

AIR PERFORMANCE (cfm)

Model	0.1"	0.2"	0.3"	Air Flow (CFM)	Sones @ 0.1	Current (Amp)	Power (watt)	RPM (nominal)	Room size Capacity	Electrical Rating
VIP70	70	61	49	73	1.5	0.21	25	1510	60 - 80 sq. ft.	120V/60Hz
VIP90	90	79	66	94	2.0	0.295	30	1675	80 - 105 sq. ft.	
VIP110	110	89	66	92	3.5	0.415	40	1630	105 - 125 sq. ft.	

MODEL	QUANTITY	COMMENTS	PROJECT
			Location:
			Architect:
			Engineer:
			Contractor:
			Submitted by:



LEXTON FANS, INC.
 5681 SOUTH DOWNEY ROAD
 VERNON, CA 90058 USA
 Phone: 323-284-2188
 Toll Free Fax: 1-866-281-8605

www.lextonfans.com

Certifications:





SPECIFICATIONS

VIP Series Ventilation Fan
MODEL#: VIP70, VIP90 & VIP110

AREA FOR A FAN CURVE:



Static Pressure (inches of w.g.):

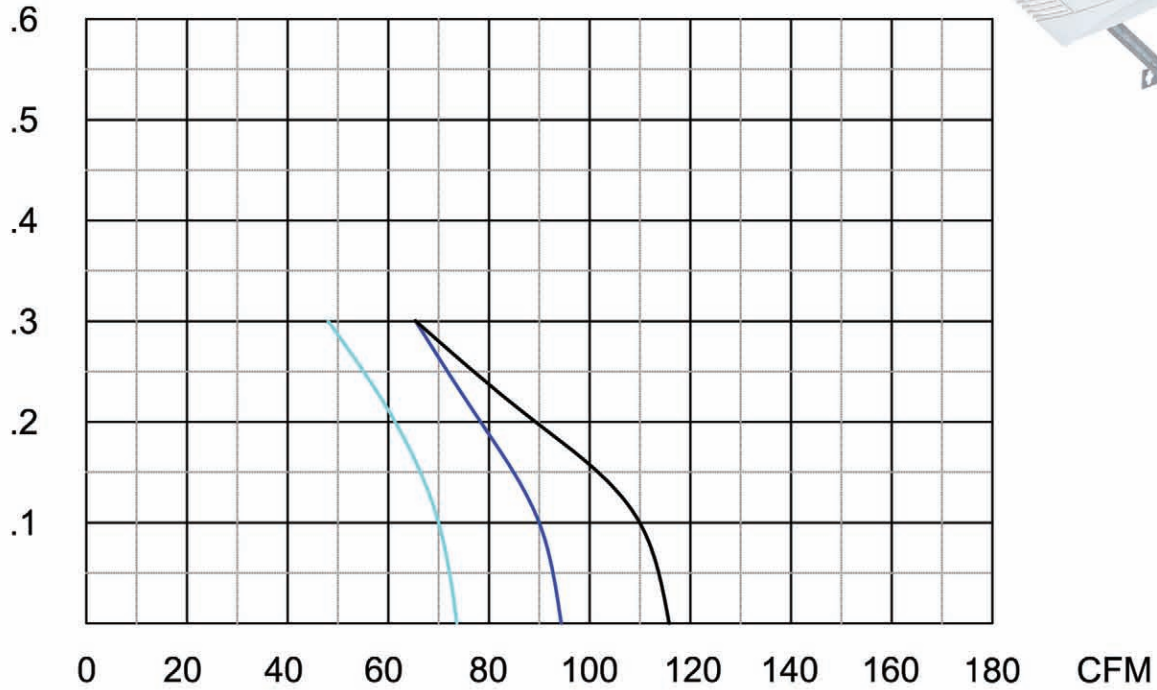

- VIP70
- VIP90
- VIP110



LEXTON FANS, INC.
5681 SOUTH DOWNEY ROAD
VERNON, CA 90058 USA
Phone: 323-284-2188
Toll Free Fax: 1-866-281-8605

www.lextonfans.com

Certifications:

