

SELECT Series Economical choice fans

Model#: PA50V & PA70V-4

DESCRIPTION - Ventilating fan shall be a quiet ceiling mount type rated for continuous run. Fan shall be tested as per AMCA or the Home Ventilating Institute (HVI) standards. Evaluated by ETL and conform to both UL and safety standards.

MOTOR/BLOWER

- * Open style, frame, removable and permanently lubricated motor.
- * Power rating shall be 120V/60Hz.
- * Fan shall be ETL listed for tub/shower enclosure when used with a GFCI branch circuit wiring.
- * Motor equipped with thermal cut-off fuse.

FAN HOUSING

- * Rust proof galvanized steel body.
- * Detachable 3" diameter duct adapter.
- * Built in backdraft damper.
- * Mounting ears for quick easy installation.
- * Housing Dimensions: 8" x 7" x 3-3/4"

GRILLE

- * Attractive design using white ABS material.
- * Grille dimensions: 7-1/8" x 7-1/8"

TYPICAL SPECIFICATIONS

Ventilating fan shall be of the ceiling mount with no less than 50 and 70 CFM and no more than 3.5 and 4.5 sones respectively, as per AMCA or the Home Ventilating Institute (HVI) standards at 0.1" static pressure in inches water gauge. The motor shall be open style, frame and permanently lubricated. Power rating shall be 120V/60Hz. Duct diameter shall be no less than 3". Fan shall be for tub/shower enclosure when used with GFCI branch circuit wiring.

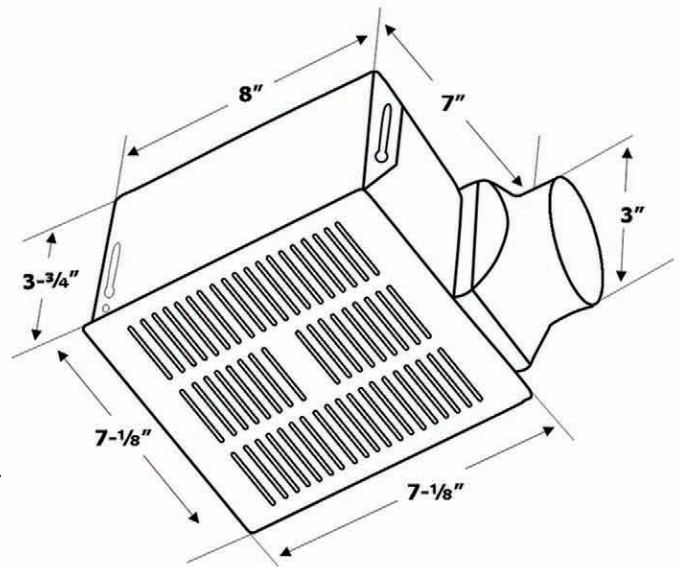

AIR PERFORMANCE (CFM)

| Model | Static pressure (inches of wg) | | | | | | | | | | | Air flow (cfm) | Sones @ 0.1 | Current (amp) | Power (watt) | RPM (nominal) | Electrical rating | Room size Capacity | |
|---------|--------------------------------|------|-------|------|-------|------|-------|------|-------|------|------|----------------|-------------|---------------|--------------|---------------|-------------------|--------------------|-----------------|
| | 0 | 0.1" | 0.15" | 0.2" | 0.25" | 0.3" | 0.35" | 0.4" | 0.45" | 0.5" | 0.6" | | | | | | | | 0.7" |
| PA50V | 58 | 52 | 50 | 48 | 46 | 43 | 40 | 33 | 20 | 13 | 13 | 13 | 50 | 2.5 | 0.27 | 46 | 1670 | 120V/60Hz | 45 - 60 sq. ft. |
| PA70V-4 | 80 | 74 | 71 | 68 | 64 | 61 | 57 | 53 | 49 | 43 | 30 | 11 | 70 | 5 | 0.37 | 58 | 2210 | 120V/60Hz | 60 - 80 sq. ft. |

| MODEL | QUANTITY | COMMENTS | PROJECT |
|-------|----------|----------|---------------|
| | | | Location: |
| | | | Architect: |
| | | | Engineer: |
| | | | Contractor: |
| | | | Submitted by: |



LEXTON FANS, INC.

5681 SOUTH DOWNEY ROAD
VERNON, CA 90058 USA

Phone: 323-284-2188

Toll Free Fax: 1-866-281-8605

www.lextonfans.com

Certifications:





SPECIFICATIONS

SELECT Series Economical choice fans

Model#: PA50V & PA70V-4



AREA FOR A FAN CURVE:

Static Pressure (inches of w.g.):

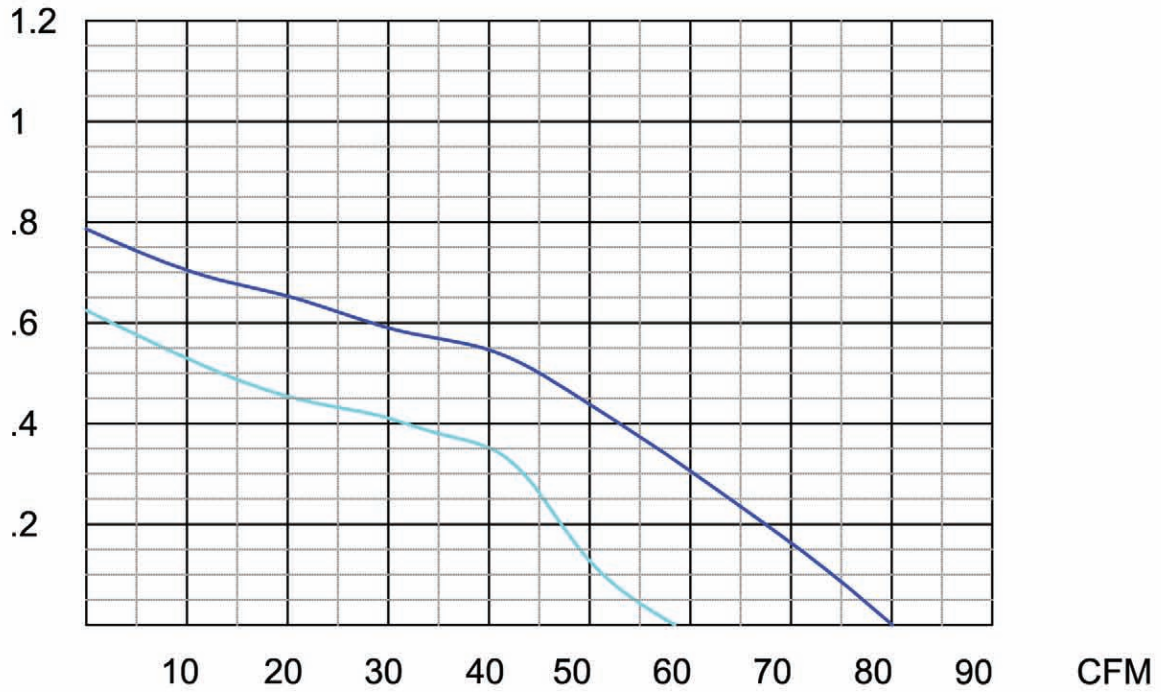

— PA50V
 — PA70V-4



LEXTON FANS, INC.

5681 SOUTH DOWNEY ROAD
VERNON, CA 90058 USA

Phone: 323-284-2188

Toll Free Fax: 1-866-281-8605

www.lextonfans.com

Certifications:

