

LA Series Metallic Exhaust Fan

MODEL#: LA12, LA15 & LA25

DESCRIPTION - Metallic exhaust fan, ceiling or wall, air and sound performance certified by AMCA. Evaluated by ETL and HVI certified.

FEATURES:

- * Ideal for residential and light commercial
- * Quiet but Powerful
- * Suitable for high static pressure application
- * European Designed External Rotor Motor Technology
- * Capacitor Start and Energy Efficient
- * Mounting Brackets for flexible positioning
- * Energy Star Compliant

HOUSING

- * Painted galvanized steel housing.
- * Housing Dimensions: See chart below.

GRILLE

- * Attractive designer metal grille.
- * Grille Dimensions: See chart below.

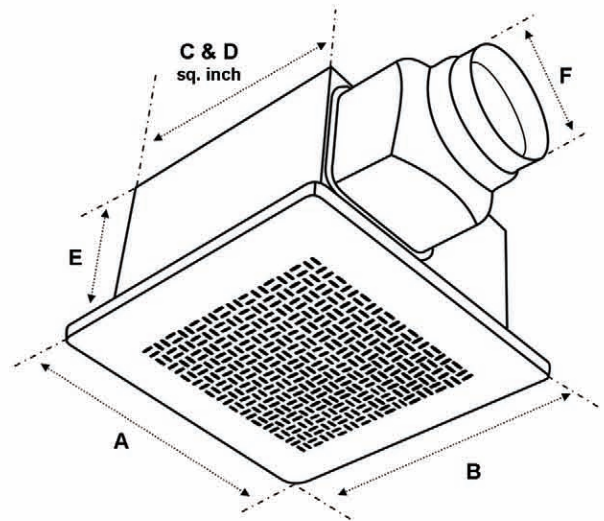

MODEL	GRILLE	UNIT		
	(A) & (B) Length (sq. inch)	(C) & (D) Length (sq. inch)	(E) Height	(F) Duct (Diameter)
LA12	13-13/16"	11-3/16"	7-5/8"	5"
LA15	13-13/16"	11-3/16"	7-5/8"	5"
LA25	19-1/16"	15-1/2"	11-1/8"	6"

AIR PERFORMANCE (CFM)

Model	Static pressure (inches of wg)											Sones @ 0.1	Current (amp)	Power (watt)	Electrical rating	Room size Capacity
	0	0.1"	0.15"	0.2"	0.25"	0.3"	0.35"	0.4"	0.45"	0.5"	0.6"					
LA12	160	137	128	118	109	100	91	82	74	66	40	1.5	0.318	40	120V/60Hz	95 - 130 sq. ft.
LA15	180	166	156	147	139	131	122	114	105	96	78	2.0	0.405	51	120V/60Hz	130 - 160 sq. ft.
LA25	317	308	298	290	282	275	267	260	249	240	220	4.0	0.793	98	120V/60Hz	250 - 300 sq. ft.

MODEL	QUANTITY	COMMENTS	PROJECT
			Location:
			Architect:
			Engineer:
			Contractor:
			Submitted by:



LEXTON FANS, INC.

5681 SOUTH DOWNEY ROAD
VERNON, CA 90058 USA

Phone: 323-284-2188

Toll Free Fax: 1-866-281-8605

www.lextonfans.com

Certifications:



LA Series Metallic Exhaust Fan

MODEL#: LA12, LA15 & LA25



AREA FOR A FAN CURVE:

Static Pressure (inches of w.g.):

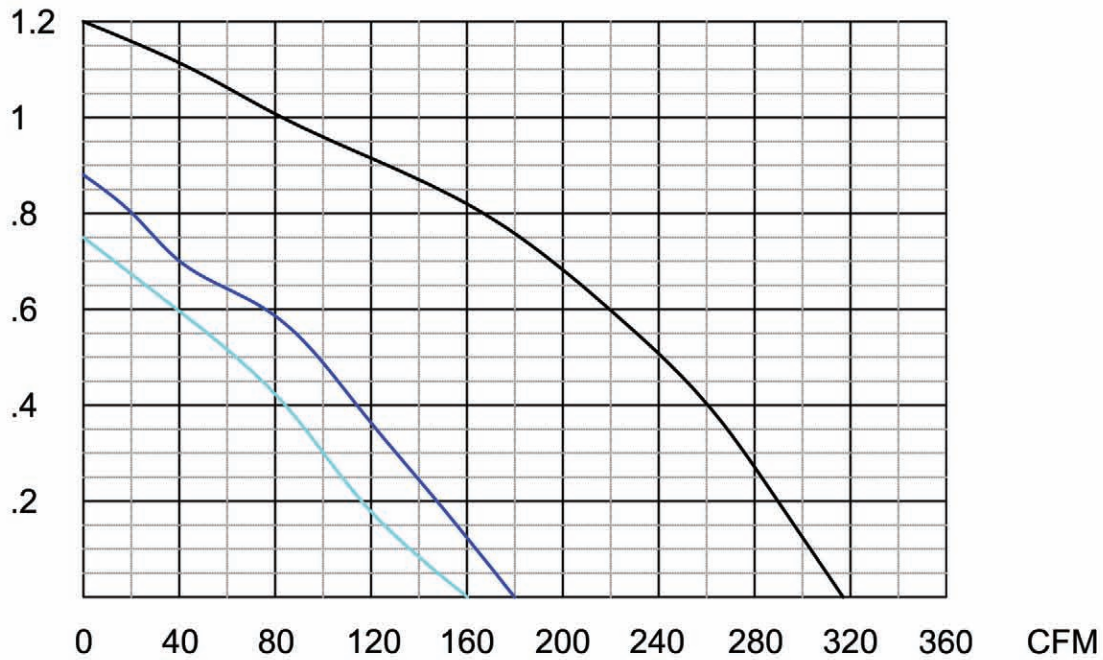

- LA12
- LA15
- LA25



LEXTON FANS, INC.

5681 SOUTH DOWNEY ROAD
VERNON, CA 90058 USA

Phone: 323-284-2188

Toll Free Fax: 1-866-281-8605

www.lextonfans.com

Certifications:

