



SPECIFICATIONS

EZM PREMIUM Series Ventilation Fan

MODEL#: EZM50 & EZM70

DESCRIPTION - Economy Ventilating Fan; Ceiling or Wall Mount
Air & Sound performance certified by HVI. Evaluated by ETL and conforms to UL safety standards.

MOTOR/BLOWER

- * Removable Motor
- * Permanently Lubricated
- * Four-Pole Capacitor Type
- * Totally Enclosed
- * Equipped With Thermal Cut Off
- * Rated for Continuous Run

FAN HOUSING

- * Galvanized steel.
- * Detachable 4" diameter duct adapter.
- * Built in detachable backdraft damper.
- * Mounts directly to joist using brackets.
- * Housing Dimensions: (refer to chart)

GRILLE

- * Attractive design using white ABS material.
- * Attaches directly to housing with torsion springs.
- * Grille Dimensions: (refer to chart)

TYPICAL SPECIFICATIONS - Ventilating fan shall be of the ceiling or wall mount with air performance and sound rating listed as per the chart below certified by HVI at 0.1" static pressure inches of water gauge; The motor shall be totally enclosed, four pole capacitor type engineered to run continuously; Power rating shall be 120V/ 60Hz. Duct diameter shall be no less than 4"; Fan shall be for tub/shower enclosure when used with GFCI branch circuit wiring.

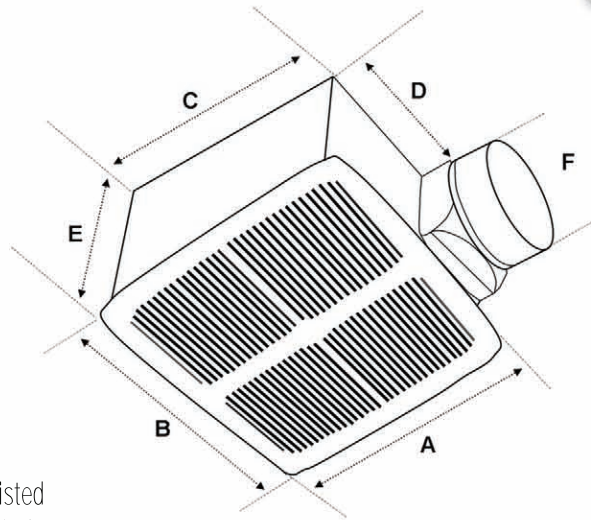

| MODEL | GRILLE | UNIT | | |
|-------|--------------------------------|--------------------------------|---------------|------------------------|
| | (A) & (B) Length (sq. inch) | (C) & (D) Length (sq. inch) | (E) Height | (F) Duct (Diameter) |
| EZM50 | 10-1/2 | 8-1/4" | 4-3/4" | 4" |
| EZM70 | | | | |

AIR PERFORMANCE (CFM)

| Model | Static pressure (inches of wg) | | | | | | | | Air flow (cfm) | Sones @ 0.1 | Current (amp) | Power (watt) | RPM (nominal) | Electrical rating | Room size Capacity |
|-------|--------------------------------|------|-------|------|-------|------|-------|------|----------------|-------------|---------------|--------------|---------------|-------------------|--------------------|
| | 0 | 0.1" | 0.15" | 0.2" | 0.25" | 0.3" | 0.35" | 0.4" | | | | | | | |
| EZM50 | 63 | 54 | 47 | 39 | 33 | 22 | 0 | 0 | 50 | 0.6 | 0.18 | 22 | 1100 | 120V/60Hz | 45 - 55 |
| EZM70 | 84 | 72 | 68 | 65 | 58 | 49 | 19 | 0 | 70 | 1.7 | 0.21 | 24 | 1020 | 120V/60Hz | 70 - 75 |

| MODEL | QUANTITY | COMMENTS | PROJECT |
|-------|----------|----------|---------------|
| | | | Location: |
| | | | Architect: |
| | | | Engineer: |
| | | | Contractor: |
| | | | Submitted by: |



LEXTON FANS, INC.

5681 SOUTH DOWNEY ROAD
VERNON, CA 90058 USA

Phone: 323-284-2188

Toll Free Fax: 1-866-281-8605

www.lextonfans.com

Certifications:





EZM PREMIUM Series Ventilation Fan

MODEL#: EZM50 & EZM70

SPECIFICATIONS



AREA FOR A FAN CURVE:

Static Pressure (inches of w.g.):

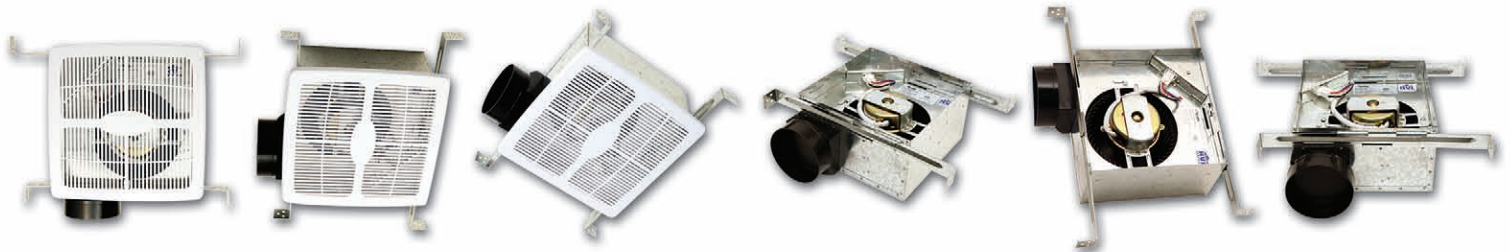
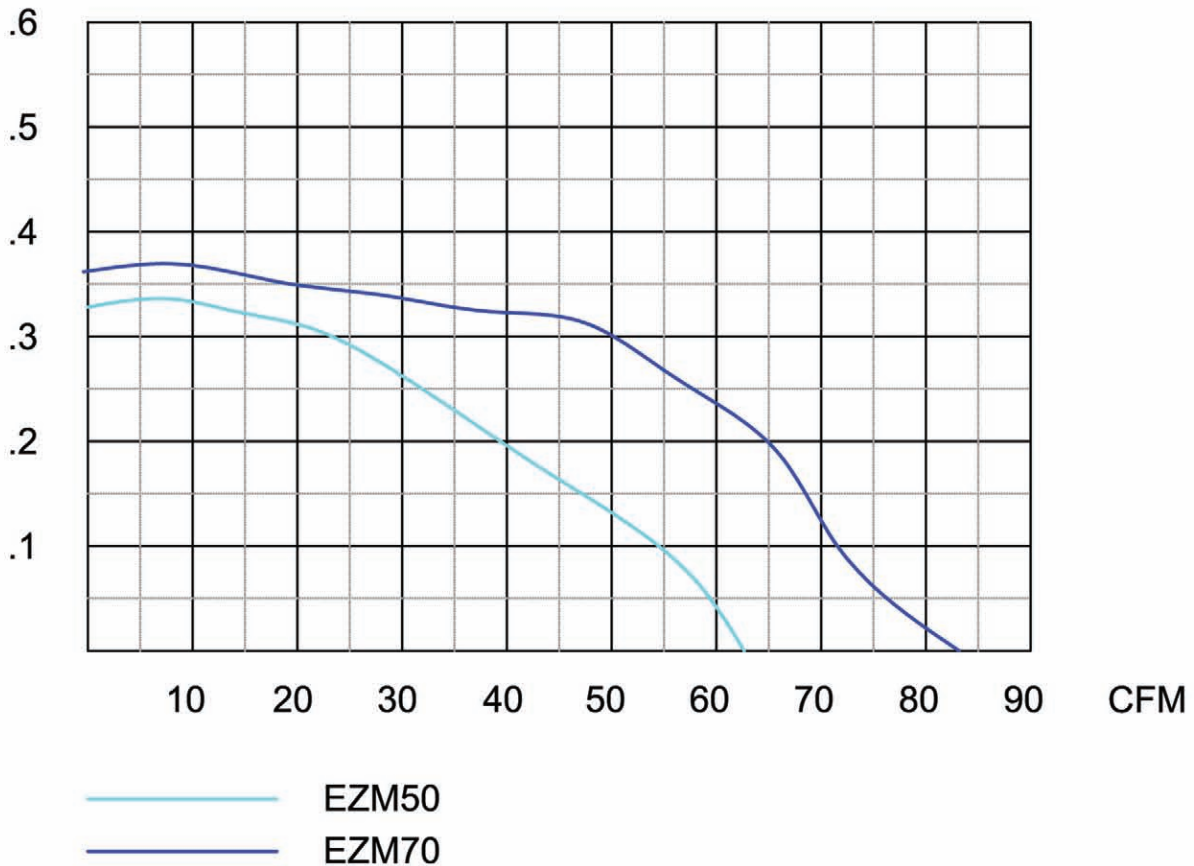

LEXTON FANS, INC.
5681 SOUTH DOWNEY ROAD
VERNON, CA 90058 USA
Phone: 323-284-2188
Toll Free Fax: 1-866-281-8605

www.lextonfans.com

Certifications:

