

## SLIM-LINE Series Exhaust Fan/Light

MODEL#: SQL500, SQL700, SQL900 & SQL1100

DESCRIPTION - Round model, low profile very quiet ventilators that can be installed within a 6" joist. Performance as noted in the table below.

### MOTOR/BLOWER

- \* 4 pole plug in motor, life time lubrication, rated for continuous use.
- \* 120V/60hz.

### FAN HOUSING

- \* Painted galvanized steel housing.
- \* Housing Dimensions: 12" x 12" x 5" deep

### GRILLE

- \* White polymeric grille complete with torsion clips for secure hold.
- \* Grille Dimensions: 14" x 14"

### LIGHTING

- \* 1x 30W Circular Lamp, 4-Pin, T10
- \* 1 x 4W Night Light Incandescent

### DUCT COLLAR

- \* 4" duct collar, weighted noiseless weighted backdraft damper.
- \* Painted galvanized steel.

### MOUNTING

- \* Rated for installation in ceilings up to R40.
- \* Double hanger bar system for ideal positioning.
- \* Expandable extension bracket up to 24"
- \* Drywall rough in opening is 12.5" in diameter.
- \* Acceptable for use over tub or shower when installed with a GFCI protected circuit.

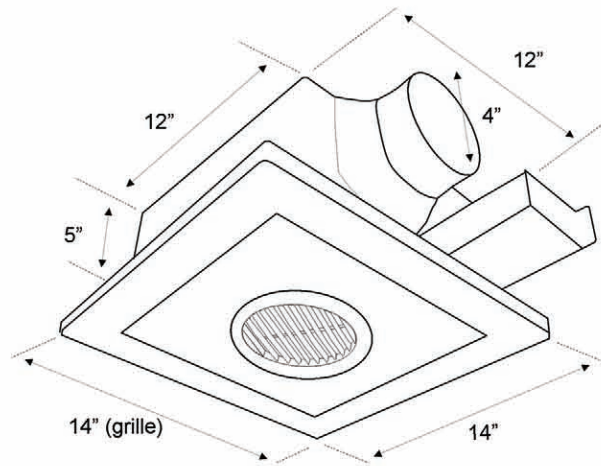

### AIR PERFORMANCE (CFM)

Model	Static pressure (inches of wg)									Air flow (cfm)	Sones @ 0.1	Current (amp)	Power (watt)	RPM (nominal)	Electrical rating	Room size Capacity
	0	0.1"	0.2"	0.25"	0.3"	0.35"	0.4"	0.5"	0.6"							
<b>SQL 500</b>	63	52	45	31						50	0.5	0.127	25	960	120V/60Hz	45 - 60
<b>SQL 700</b>	81	72	64	52	41					70	0.7	0.159	28	1040	120V/60Hz	60 - 80
<b>SQL 900</b>	100	93	87	71	66	52	35			90	0.9	0.16	37	1120	120V/60Hz	80 - 100
<b>SQL 1100</b>	125	112	103	98	92	72	72	54	32	110	1.5	0.252	40	1270	120V/60Hz	100 - 120

MODEL	QUANTITY	COMMENTS	PROJECT
			Location:
			Architect:
			Engineer:
			Contractor:
			Submitted by:



**LEXTON FANS, INC.**

5681 SOUTH DOWNEY ROAD  
VERNON, CA 90058 USA

Phone: 323-284-2188

Toll Free Fax: 1-866-281-8605

[www.lextonfans.com](http://www.lextonfans.com)

Certifications:





# SPECIFICATIONS

SLIM-LINE Series Exhaust Fan/Light  
MODEL#: SQL500, SQL700, SQL900 & SQL1100



AREA FOR A FAN CURVE:

**Static Pressure (inches of w.g.):**

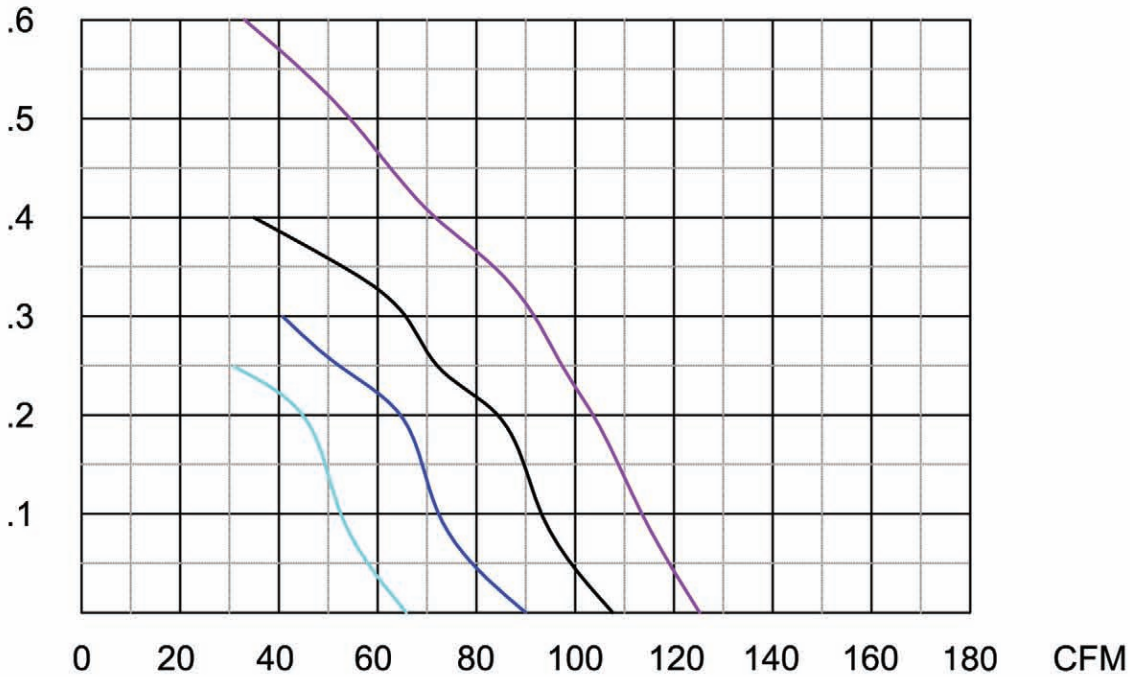

- SQL500
- SQL700
- SQL900
- SQL1100



**LEXTON FANS, INC.**  
5681 SOUTH DOWNEY ROAD  
VERNON, CA 90058 USA  
Phone: 323-284-2188  
Toll Free Fax: 1-866-281-8605

[www.lextonfans.com](http://www.lextonfans.com)

Certifications:

