



SPECIFICATIONS

PREMIUM PLUS Ventilation Fan (Jumbo)

MODEL#: JB150, JB200, JB300 & JB400

DESCRIPTION - Ventilating fan shall be quiet ceiling mount type rated for continuous run. Fan shall be tested as per AMCA or the Home Ventilating Institute (HVI). Evaluated by ETL and conform to UL safety standards.

MOTOR/BLOWER

- * Four-pole totally enclosed capacitor motor rated for continuous run.
- * Power Rating shall be 120V/ 60Hz.
- * Fan shall be ETL listed for tub/shower enclosure when used with a GFCI branch circuit wiring.
- * Motor with thermal cut-off fuse.
- * Removable, permanently lubricated plug-in motor.

FAN HOUSING

- * Rust proof paint, galvanized steel body.
- * Built in backdraft damper.
- * Expandable extension brackets up to 24".
- * See chart below for duct & housing dimensions.

GRILLE

- * Attractive design using PP material.
- * Attaches directly to housing with torsion springs.
- * Refer to chart below for grille size info.

TYPICAL SPECIFICATIONS

Ventilating fan shall be of the ceiling mount with no less than stated in the following chart as per AMCA or the Home Ventilating Institute (HVI) standard at 0.1 static pressure in inches of water gauge. The motor shall be totally enclosed. four pole capacitor type engineered to run continuously. Power rating shall be 120V/60Hz. Duct diameter shall be no less than 6". Fan shall be ETL listed for tub/shower enclosure when used with GFCI branch circuit wiring.

AIR PERFORMANCE (CFM)

| Model | Static pressure (inches of wg) | | | | | | | | | | Air flow (cfm) | Sones @ 0.1 | Current (amp) | Power (watt) | RPM (nominal) | Electrical rating | Room size Capacity (sq/ft) |
|--------------|--------------------------------|------|------|-------|------|-------|------|------|------|------|----------------|-------------|---------------|--------------|---------------|-------------------|----------------------------|
| | 0 | 0.1" | 0.2" | 0.25" | 0.3" | 0.35" | 0.4" | 0.5" | 0.6" | 0.7" | | | | | | | |
| JB150 | 176 | 157 | 146 | 142 | 135 | 128 | 119 | 97 | 64 | 24 | 150 | 0.9 | 0.23 | 42 | 780 | 120V/60Hz | 125 - 190 |
| JB200 | 257 | 234 | 217 | 209 | 198 | 165 | 184 | 169 | 140 | 120 | 200 | 2.5 | 0.40 | 135 | 960 | 120V/60Hz | 190 - 250 |
| JB300 | 395 | 372 | 326 | 316 | 303 | 280 | 279 | 255 | 231 | 210 | 300 | 3.5 | 0.50 | 125 | 1260 | 120V/60Hz | 250 - 350 |
| JB400 | 445 | 410 | 382 | 366 | 348 | 321 | 312 | 275 | 236 | 208 | 400 | 4.5 | 0.61 | 135 | 960 | 120V/60Hz | 350 - 450 |

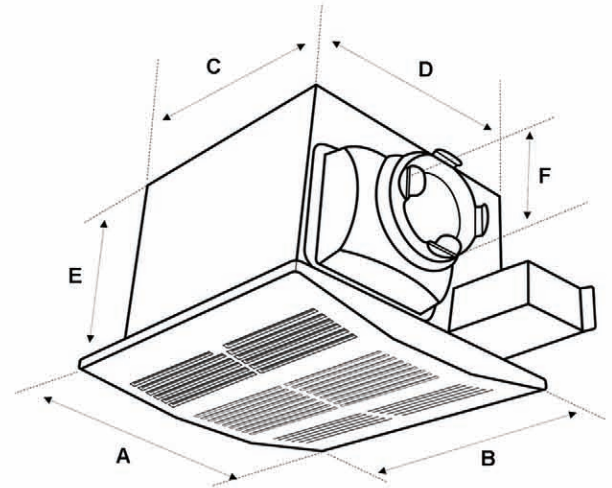

| Model# | Grille | Housing | Duct |
|---------------|-------------------|----------------------------|------|
| | (A) x (B) | (C) x (D) x (E) | (F) |
| JB 150 | 12 3/4" x 12 3/4" | 10 1/4" x 10 1/4" x 7 7/8" | 6" |
| JB 200 | 12 3/4" x 12 3/4" | 10 1/4" x 10 1/4" x 7 7/8" | 6" |
| JB 300 | 13 3/4" x 13 3/4" | 11 15/16" x 11 15/16" x 9" | 6" |
| JB 400 | 16 1/4" x 16 1/4" | 14 1/2" x 14 1/2" x 9" | 6" |

| MODEL | QUANTITY | COMMENTS | PROJECT |
|-------|----------|----------|---------------|
| | | | Location: |
| | | | Architect: |
| | | | Engineer: |
| | | | Contractor: |
| | | | Submitted by: |



LEXTON FANS, INC.
 5681 SOUTH DOWNEY ROAD
 VERNON, CA 90058 USA
 Phone: 323-284-2188
 Toll Free Fax: 1-866-281-8605

www.lextonfans.com

Certifications:





SPECIFICATIONS

Premium Plus Ventilation Fan (Jumbo)

MODEL#: JB150, JB200, JB300 & JB400



AREA FOR A FAN CURVE:

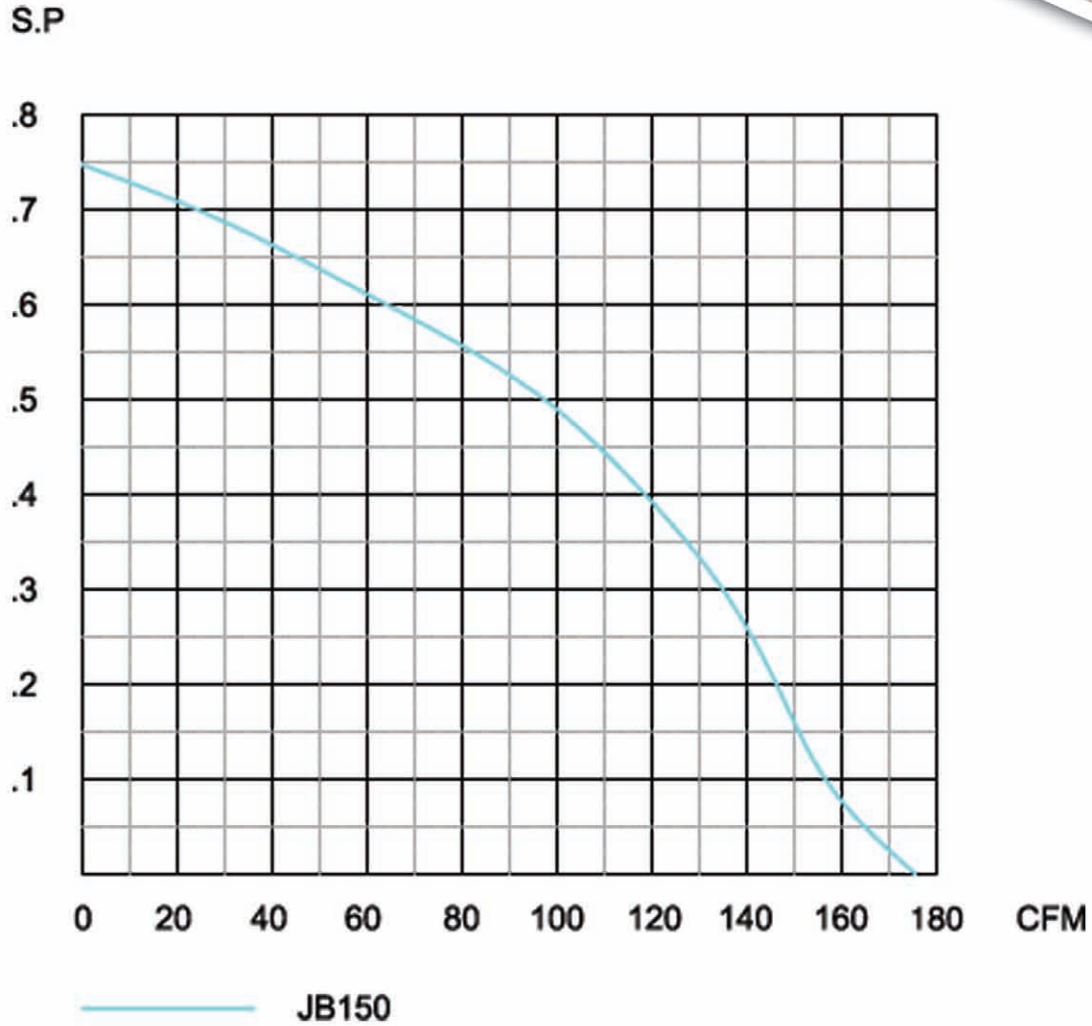

LEXTON FANS, INC.

5681 SOUTH DOWNEY ROAD
VERNON, CA 90058 USA

Phone: 323-284-2188

Toll Free Fax: 1-866-281-8605

www.lextonfans.com

Certifications:

