

Premium Quiet Series Ventilation Fan

MODEL#: PA500V, PA700V, PA900V & PA1100V

DESCRIPTION - Very quiet ventilation fan with performance as noted in the table below.

BODY - This is made from painted heavy gauge sheet metal for protection against rusting.

MOTOR - It is lifetime lubrication for constant running without failure or making noise. 4 pole plug in motor, rated for continuous use. 120V/60Hz.

FAN HOUSING

- * Painted galvanized steel housing.
- * Housing Dimensions: 9-1/16" x 9-1/16" x 7-3/4"

GRILLE

- * White polymeric grille complete with torsion clips for secure hold.
- * Grille Dimensions: 12-1/16" x 12-1/16"

DUCT COLLAR

- * 4" duct collar, weighted noiseless backdraft damper.
- * Painted galvanized steel.

MOUNTING

- * Rated for installation in ceilings up to R40.
- * Double hanger bar system for ideal positioning.
- * Expandable extension bracket up to 24".
- * Drywall Rough in opening is 9" x 9".
- * Acceptable for use over tub or shower when installed with a GFCI protected circuit.

FIRE SHIELD FIRE RADIATION DAMPER

Use Model 0750HM – UL approved for US & Canada.

AIR PERFORMANCE (CFM)

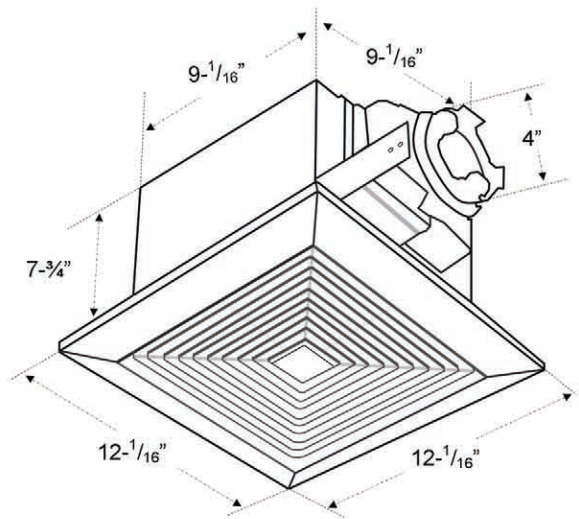

Model	Static pressure (inches of wg)										Air flow (cfm)	Sones @ 0.1	Current (amp)	Power (watt)	RPM (nominal)	Electrical rating	Room size Capacity
	0	0.1"	0.15"	0.2"	0.25"	0.3"	0.35"	0.4"	0.45"	0.5"							
PA500V	76	58	48	34	15	2					50	0.3	0.127	13	975	120V/60Hz	45 - 60 sq. ft.
PA700V*	90	77	70	62	53	44	24	6			70	0.4	0.159	20	1050	120V/60Hz	60 - 80 sq. ft.
PA900V*	108	98	92	86	82	73	67	56	37	7	90	0.7	0.16	27	1110	120V/60Hz	80 - 100 sq. ft.
PA1100V*	120	110	105	98	92	87	80	63	40	7	110	1.3	0.252	35	1375	120V/60Hz	100 - 120 sq. ft.

MODEL	QUANTITY	COMMENTS	PROJECT
			Location:
			Architect:
			Engineer:
			Contractor:
			Submitted by:



LEXTON FANS, INC.

5681 SOUTH DOWNEY ROAD
VERNON, CA 90058 USA

Phone: 323-284-2188

Toll Free Fax: 1-866-281-8605

www.lextonfans.com

Certifications:





SPECIFICATIONS

PREMIUM QUIET Series Ventilation Fan

MODEL#: PA500V, PA700V, PA900V & PA1100V



AREA FOR A FAN CURVE:

Static Pressure (inches of w.g.):

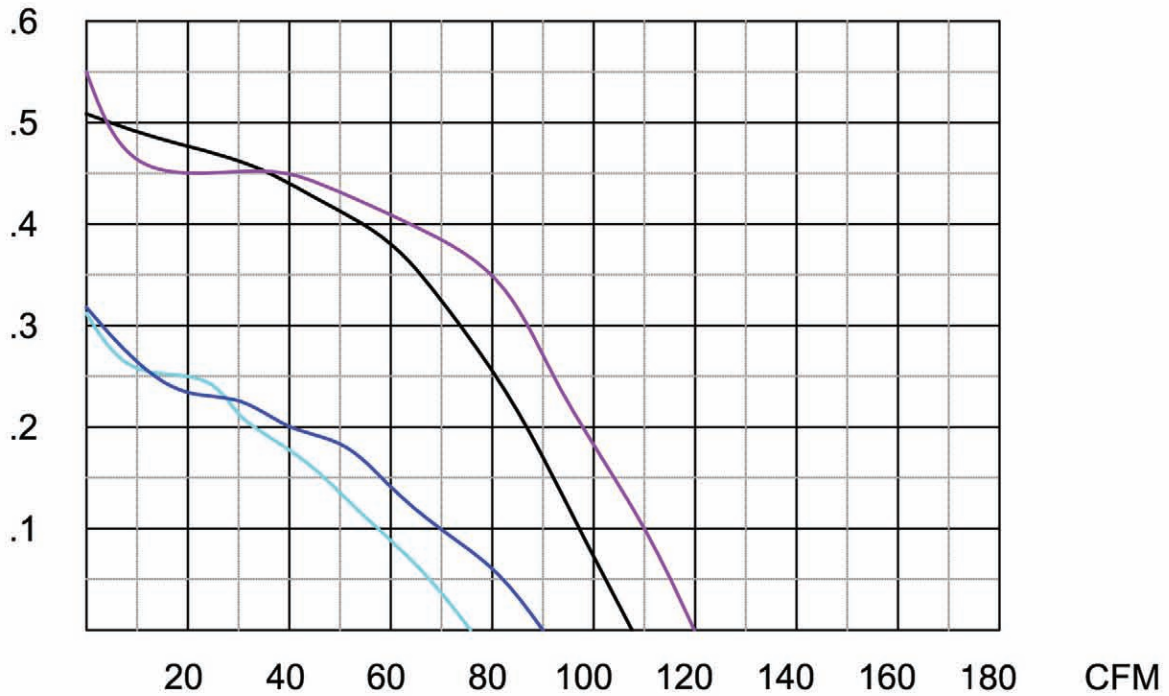

- PA500V
- PA700V
- PA900V
- PA1100V



LEXTON FANS, INC.

5681 SOUTH DOWNEY ROAD
VERNON, CA 90058 USA

Phone: 323-284-2188
Toll Free Fax: 1-866-281-8605

www.lextonfans.com

Certifications:

